



THE CASE FOR EVOLVED EDGE

AUGUST 2008

The Evolution of GSM EDGE

The GSM Landscape

GSM technology services the largest percentage of mobile users in the world today and is available universally across the world. As of August 2008 there were 718 GSM operators in 220 countries worldwide, with over 3 billion GSM/UMTS subscriptions. Additionally, at the same point in time there were over 350 million UMTS/HSPA subscriptions¹.

The world's biggest GSM markets today are China (509 million), which is growing at a rate of more than 7 million new connections a month and accounts for 14% of the "third billion" growth; India (193 million), growing at 6 million per month accounts for 12% of the "third billion" growth, Russia (178 million) and Brazil (93 million) that both contributed 4% of the "third billion" growth. New connections are being added at the rate of 15 per second, or 1.3 million per day.

"The growth of mobile communications continues to soar, not least in emerging markets, which are responsible for 85 percent of new connections today," said Rob Conway, CEO and Board Member of the GSMA. "One cannot underestimate the importance of mobile as a vital communications tool, connecting so many people, often for the first time in their lives."²

GSM is deployed in common harmonized spectrum consisting primarily of four frequency bands: 850MHz, 900MHz, 1800MHz and 1900MHz. More GSM bands are available; these are fully described in 3GPP TS 45.005 section 2. In 2008, the GSM family of technologies (GSM, EDGE, UMTS/HSPA) represented 88% of the worldwide mobile market for voice and data services – forming the baseline voice and data fabric for the world. The continued growth of GSM networks is driven by economic forces of which the main ones are economies of scale and readily available experience in operating such networks.

The GSM system has been continually enhanced. The packet data GPRS overlay on GSM offered peak downlink and uplink data rates of up to 80kbps, with typical rates in the 20-50kbps range. EDGE standardization was finalized in 2000 and provided a significant enhancement over GSM and GPRS. EDGE offers peak downlink data rates of 473.6kbps and peak uplink data rates of 236.8kbps³. Dual Transfer Mode for GSM allows the simultaneous operation of circuit switched and packet switched connections on the same carrier frequency.

¹ Source: Informa Telecoms & Media, World Cellular Information Service, updated August 2008

² Source: GSMA Press Release

http://www.gsmworld.com/news/press_2008/press08_31.shtml

³ Source: Table 4, "EDGE, HSPA and LTE – The Mobile Broadband Advantage" – Rysavy Research Sept. 2007

Upgrading from GPRS to EDGE has become a natural step for many operators:

- EDGE uses the same radio resource definition as GSM/GPRS, therefore does not require special deployment or additional spectral resources, other than to accommodate additional loading and capacity
- EDGE is more efficient compared with GPRS offering three times the peak data rate with the same spectrum requirement
- The move to EDGE was a software upgrade to most recent Base Transceiver Stations (BTS) and Base Station Controllers (BSC) as many BTS and BSC were already EDGE capable
- EDGE is a practical and complementary technology to UMTS deployments – especially seen in the light of service continuity, where a user moves between UMTS/HSPA and GPRS/EDGE coverage and still receives a good user experience.

The uptake on the EDGE enhancement is clear: there are more than 360 operators in service or committed to service in 165 countries across the world⁴.

GSM/EDGE networks will continue to form the basis for global mobile voice and data for the foreseeable future because:

- Some regions do not have the licensed spectrum and resources to install a completely new radio technology such as UMTS/HSPA or LTE
- For customers in emerging markets, the retail price for a single radio GSM/EDGE handset is lower than the retail price of smartphones that include more than one radio access technology
- There are many viable services that can be supported and are therefore available across the globe in a roaming context.

The EDGE enhancement to GPRS data service over GSM is now available even in low and mid tier handsets. Virtually all GSM smartphones and dual mode GSM/3G phones have EDGE capability, since the GSM network is the fallback radio network for roamers in different countries as well as in rural areas and EDGE capability provides for the best data service continuity available today.

Evolved EDGE is a further data service enhancement to GSM, which continues to leverage the maturity of GSM voice and core network functionalities. It is standardized in Release 7 of the GSM specifications. Enhancements to GSM are continuing, including optimizing the A interface between the Media Gateway and Base Station Subsystem (BSS) to work over IP connections and increasing the

⁴ Source: Informa Telecoms & Media, World Cellular Information Service, updated August 2008

hardware efficiency by increasing the number of voice users that are carried on a timeslot. These enhancements are described in more detail in Appendix A.

Why Evolve EDGE?

Considering that GSM/EDGE is expected to be the “low cost” mobile technology deployed across the globe, the GERAN radio group in 3GPP undertook a review to identify what kind of additional performance could be obtained for this technology.

Evolved EDGE will provide the following benefits:

- Increase the mean, minimum and peak data rates of GSM/EDGE networks
- Continue to be a viable and complementary technology to improvements in UMTS networks as seen in HSPA and soon in LTE, such that applications in these improved networks can continue to be viable when they roam into non-HSPA or LTE coverage areas
- Preserve Dual Transfer Mode operation, as all the Evolved EDGE enhancements are compatible with this feature
- Reduce system latency
- Improve the user experience for the most widely used mobile applications including messaging, web browsing and enabling high speed data for mobile internet business
- Improve capacity and efficiency for operators without incurring complex and costly upgrades to either BTS or core networks
- Improve cell coverage

The combination of an increase in mean and minimum data rates and a decrease in latency makes applications work better for everyone. Features that boost the system capacity allow the network to handle increased data volumes.

The motivation for Evolved EDGE is described in detail in the Feasibility Study for Evolved GSM/EDGE Radio Access Network (3GPP TS 45.912 v.7.2.0). Section 4 of this document lists the general objectives, the performance objectives and the compatibility requirements that the work focused on.

Consider for example an operator with both GSM/EDGE and UMTS/HSPA or LTE networks. The deployed technologies are required to interoperate because UMTS/HSPA or LTE deployments in many geographical areas do not or will not provide full coverage. As a user currently in an area of UMTS/HSPA or LTE coverage moves to an area without, there is the possibility of a severe data rate mismatch that may make some applications fail because they are no longer viable.

As operators consider their upgrade path from UMTS to HSPA and beyond they are enabling higher bandwidth applications. If at the same time they do not consider

upgrading their current GSM or EDGE networks, the possibility of a poor customer experience increases. Figure 1 shows the peak achievable speeds in the downlink for HSDPA and for the GSM/EDGE family of technologies. The rate disparity between HSDPA and GPRS means that many applications that may be enjoyed with HSDPA coverage may work very poorly or not at all if the mobile moves to an area with GPRS coverage only. If the mobile moves to an area with EDGE coverage, the rate change is slightly less severe but still may prohibit the use of some applications. However with Evolved EDGE, the data rates are such that most applications will work with acceptable performance as the mobile station moves.

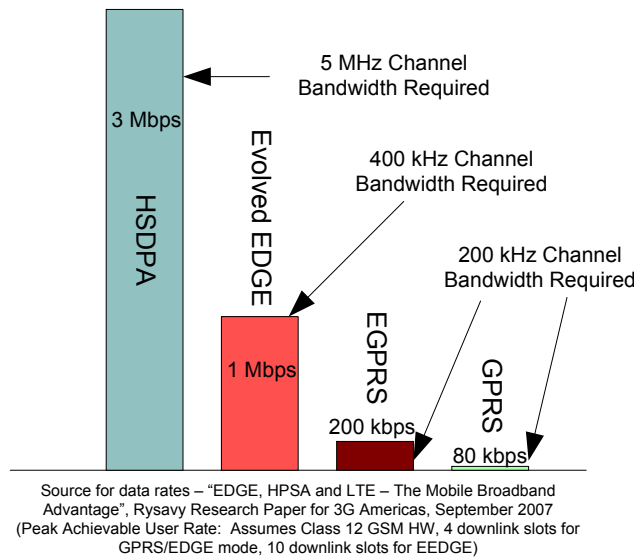

Figure 1 - Peak Achievable Downlink Data Speeds

In Figure 2, a web download application is illustrated by plotting download times of a CNN test page over various GSM networks. It can clearly be seen how with GPRS and older EDGE networks web browsing downloads take a considerable amount of time. However even a conservative estimate at Evolved EDGE achievable downlink data rates (400kbps) makes web browsing a much more viable application. This makes an Evolved EDGE network a good compliment for HSPA for mobile users with this type of data application.

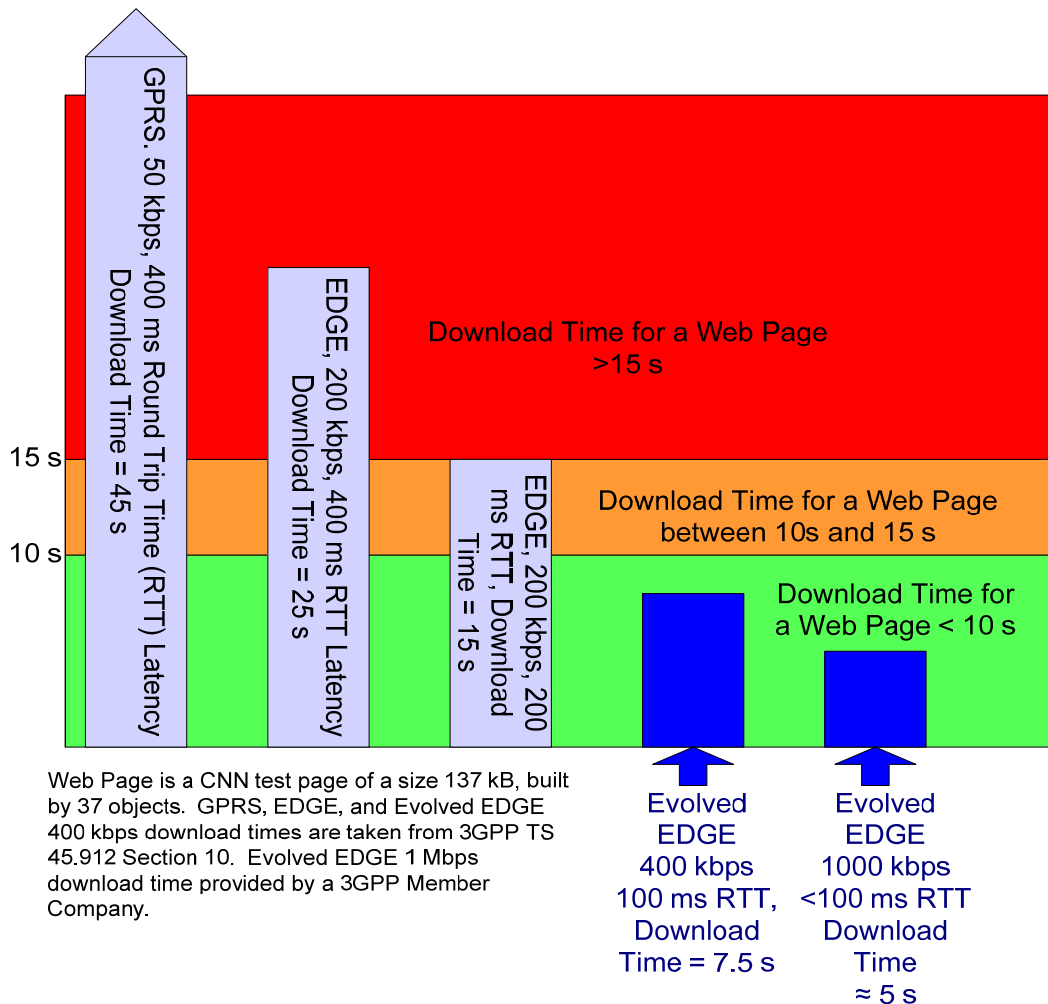

Figure 2 - Web Page Download Time Comparison

The feature set that comprises Evolved EDGE can improve the data rate of GSM networks to a peak downlink throughput of 1.2Mbps and a peak uplink throughput of 473kbps, while increasing spectral efficiency, capacity and coverage. As with previous enhancements to GSM, these features have the benefit of working within the spectrum that exists today, without new requirements. The feature set was chosen such that wherever possible, gains from each feature could be achieved with a software upgrade for newer GSM BTS, with no changes required to the core network. For higher order modulation with higher symbol rate, a new transceiver card for the BTS is likely required to achieve the highest level of additional gains. In this case, new TRX can be added to the existing TRX. Table 1 in 3GPP TS 45.912 describes each of the proposals that have been standardized and looks at their compatibility with the objectives of the Evolution. This information is summarized in Figure 3.

Coexistence and Implementation Matrix Evolved EDGE Features with Current Networks and Mobile Stations	Coexistence with Legacy Frequency Planning	Will Operation of Legacy MS be effected?	BTS Hardware Impact?	Mobile Station Impact?	Core Network Impact?
Receiver Diversity in the Mobile Station	Yes	No	No Impact	Hardware Change	None
Downlink Dual Carrier	Yes	No	No Impact	Hardware Change	None
Higher Order Modulation	Yes	No	Most Recent TRX are Capable	HW and SW Change or SW Change only	None
Higher Order Modulation and Increased Symbol Rate	Yes	No	New TRX Required	HW Change Likely	None
Latency Reduction	Yes	No	No Impact	Software Change	None

Figure 3 - Coexistence Matrix for Evolved EDGE Features

The Feature Set of Evolved EDGE

Evolved EDGE is a data enhancement to the GSM standards comprised of four optional features.

Latency Reduction

End-to-end system latency is one of the most sensitive parameters that affect data throughput. EDGE is latency-bound, which is to say that even if the air interface were capable of hundreds of megabits per second, the actual data transfer rates for some types of traffic may not increase at all. Enhancements to reduce latency are extremely important, not only for conversational voice services over IP but also for services that run over TCP/IP. The 3GPP requirement is to achieve latency below 100ms on the radio interface. Two enhancements are combined to achieve an overall improvement in latency; reduction of the transmission time interval and increased efficiency of acknowledging received data. Reducing the transmission time interval gives benefits across all radio conditions, whereas improving the efficiency in acknowledged mode of operation provides the highest benefit in poor channel conditions where the number of retransmissions can be large.

Reducing the overall latency has an important second order effect on mean/average and peak bit rates as well, since as the bit rate on the link becomes higher the maximum buffer window size can limit the transmission rate. Therefore there is limited advantage to increasing the data throughput without also decreasing the latency, as the latency becomes a limiting and increasingly significant limiting factor.

Figure 4⁵ shows how with a typical EDGE download rate of 200kbps, the latency has a very large impact on the time to download a web page.

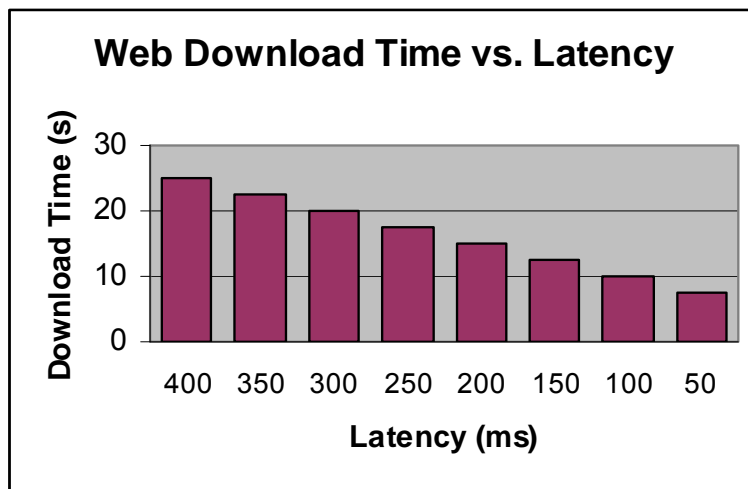

Figure 4 - Web Page Download Time: Fixed Throughput (200kbps) and Varying Latency

Implementing reductions in latency comes at a very low cost as this feature can be implemented with a software upgrade for the BTS and for most EDGE capable mobile stations. This should facilitate the rapid introduction of this feature to the market.

Downlink Dual Carrier

Downlink dual carrier helps to overcome a fundamental limitation of GSM, which is the 200kHz channel bandwidth. Several benefits can be realized by adding the ability to assign timeslots on a second carrier to one mobile station.

The most obvious benefit is that the throughput to one user can be increased by 100 to 150% over what is achievable in a single carrier capable mobile of the same multislots class. If the overall throughput requirements of the user have not increased, then the data can be transferred in a shorter period of time. This means that the mobile station can process the data more quickly leading to more responsive applications and an improved subscriber experience.

Delivering the downlink data to the mobile station more quickly also means that more time (and therefore more throughput) in the uplink is accessible. For instance a mobile station that is currently allocated four timeslots in the downlink may only be able to use two timeslots in the uplink. If the downlink timeslots are shared between

⁵ Source: 3GPP TS 45.912, Section 10.1.1.1 Figure 287.

two carriers, then the duration of downlink data transfer is only two timeslots, which leaves time to utilize four timeslots in the uplink in the same frame.

Downlink dual carrier adds to the available single user throughput and has the added advantage that it increases the flexibility in bandwidth allocation. The probability of finding contiguous timeslots on one carrier decreases as network loading increases, as shown in Figure 5⁶. The network can form a larger assignment if it can choose timeslots from more than one carrier frequency. This increases the statistical likelihood of the network using a greater number of radio resources over a given period of time, which increases system efficiency.

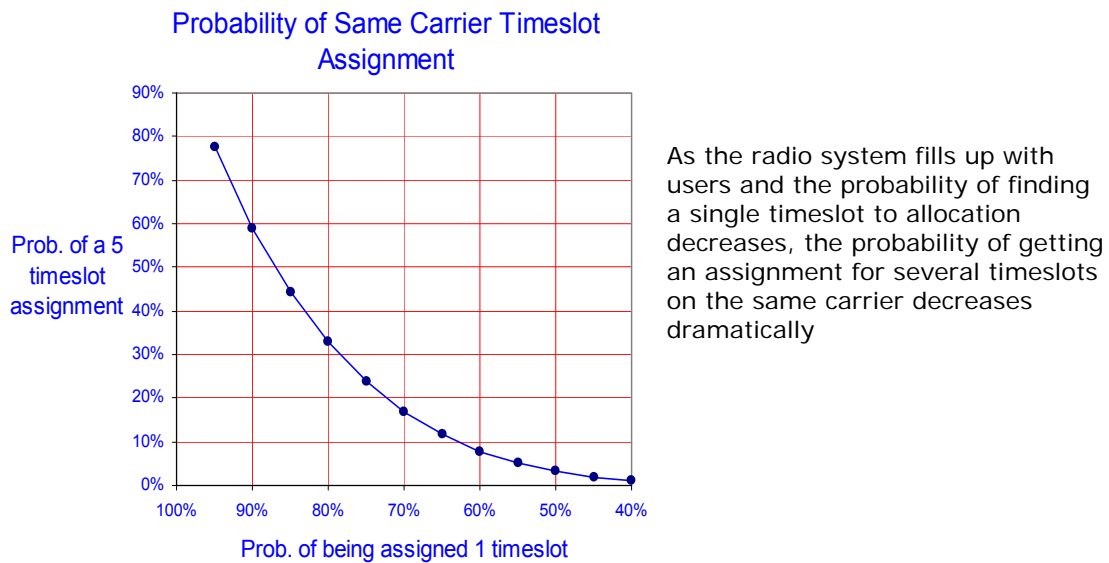

With two carriers, only half the slots need to be found on a single carrier frequency to get the same throughput. The probability of successfully using "stranded" timeslots increases which improves network efficiency.

Figure 5 - Efficiency Enhancements from Downlink Dual Carrier

Implementing downlink dual carrier in the BTS is a simple software upgrade and comes at a very low cost; however new mobile handsets will be required.

Higher Order Modulation and Higher Symbol Rate

Higher order modulation takes advantage of margin in the radio link, which may exist in many locations within a cell. This feature introduces new higher order modulation schemes and also introduces an increased symbol rate which further enhances the throughput rate over the same channel with the same modulation.

⁶ Source: Figure from "A Sharper EDGE – The Evolution of GSM", Research In Motion, 2008.

The introduction of these enhancements results in higher peak throughput per timeslot, making the transmission more efficient. This reduces the data session airtime, allowing radio resources to be released more quickly for the same data transfer. This leads to OPEX savings for the network as more users can be supported on the same hardware, and battery savings on the mobile station.

Link level gains across the full range of carrier to interference ratio are shown in Figure 6⁷ and Figure 7⁷. The user scenarios shown is a typical urban environment with a user speed of 3 km/h, with ideal frequency hopping applied. Antenna diversity is not applied in the uplink and receive diversity is not applied in the downlink. Higher order modulation can be supported by many BTS already deployed in the field without major modifications to the transceiver (TRX) (a software upgrade is required). Implementing increased symbol rates will likely require new TRX cards in the BTS. Gains with and without higher symbol rate applied are shown in the following figures⁸.

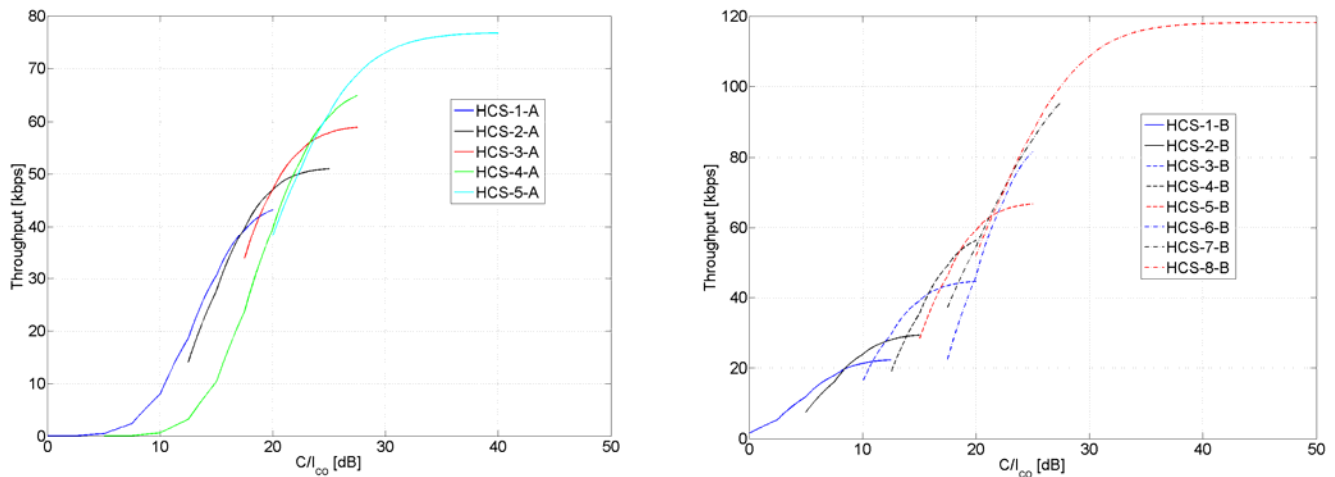

Figure 6 - Throughput for EGPRS2 Uplink with and Without Higher Symbol Rate Applied

⁷ Source: Figures taken from 3GPP TDoc GP-071242, Dublin, Ireland, August 2007.

⁸ The throughput rates shown for the downlink for Higher Order Modulation with Higher Symbol Rate assume that a wide bandwidth pulse shaping filter is applied. Rates with the legacy pulse shaping filter as specified for Release-7 will be reduced from what is shown. The names of the modulation and coding schemes adopted in the 3GPP specifications are not the same as what are shown in these figures.

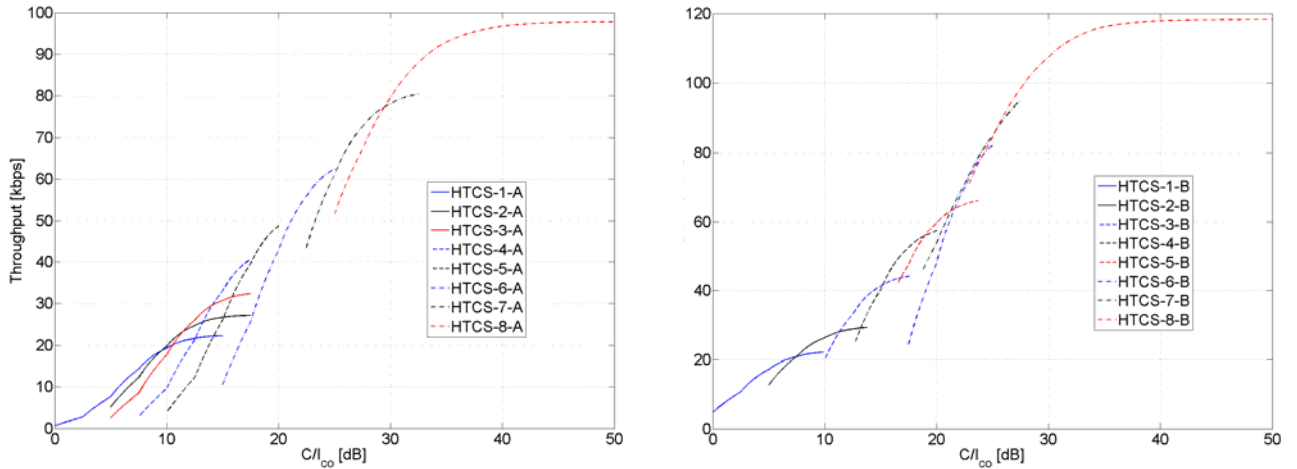

Figure 7 - Throughput for EGPRS2 Downlink with and Without Higher Symbol Rate Applied

In system level analysis with various reuse scenarios and network loading, it has been shown that the downlink throughput gains are present for users everywhere in the cell. For users in bad radio conditions the gain ranged from 13-60%. For the median users, the gain is 34-45%, while for the users in the best signal to noise environments the gain is 34-38%⁹. The use of turbo codes in the downlink contributes to these gains. Advanced receivers were not used in the system level analysis.

New mobile handsets are also likely to be required; however the latest UMTS/HSPA capable handsets may be capable of supporting this feature without significant hardware changes.

Mobile Station Receive Diversity

Receive diversity capability in the mobile station increases sensitivity and robustness in areas of high interference and dense deployment. This can translate into a significant downlink network capacity improvement if the mobile penetration rate is high.

⁹ Source: System simulation data taken from 3GPP temporary document (TDoc) GP-062120, "System Level Performance of HOTA", Source: Ericsson, November 2006.

If the penetration of Mobile Station Receive Diversity (MSRD) mobiles is low, then mobile stations that support MSRD will see higher average throughput across the entire SNR range. The gains realized with the introduction of MSRD allow the network to assign higher modulation and coding schemes to the mobile station. According to link level simulations, this gives in an increase in the average downlink throughput of around 30% compared to conventional receivers. This is illustrated in Figure 8¹⁰.

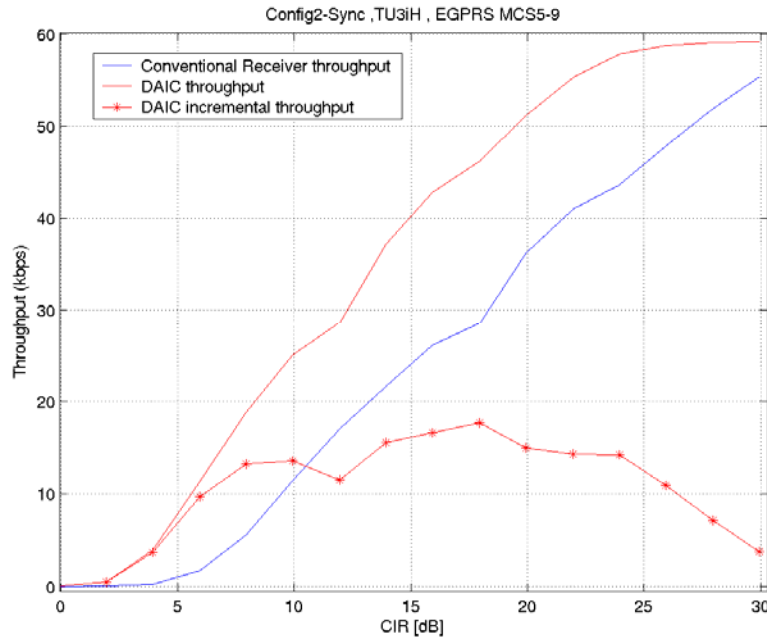

Figure 8 - MSRD Throughput Gains

The enhanced receiver performance also results in greater coverage by the mobile station. This permits the BTS to use power control to reduce the output power to an MSRD capable mobile station, reducing interference across the cell which benefits capacity. System simulations have shown that using MSRD together with the downlink advanced receiver performance (DARP - specified in Release 6) more than doubles the voice capacity while preserving good voice quality¹¹.

¹⁰ Source: 3GPP TS 45.912, "Feasibility Study for Evolved GSM/EDGE Radio Access Network (GERAN)", Figure 40.

¹¹ Source: 3GPP TS 45.912, "Feasibility Study for Evolved GSM/EDGE Radio Access Network (GERAN)", Table 15.

	Conventional Receiver	DARP	DARP+Receive Diversity	DARP+Receive Diversity
Flat, 3 km/hr	32 %	45 %	84 %	85 %
Flat, 50 km/hr	30 %	42 %	80 %	82 %
TU, 3 km/hr	-	64 %	84 %	-
TU, 50 km/hr	-	58 %	83 %	-

Table 1 - System Voice Capacity Comparison with Receive Diversity

Due to the implementation complexity, initially there may be a noticeable penalty to the handset in terms of cost and size, which may make this feature more easily supported on an advanced multi-mode smartphone and less easily supported on EDGE single mode devices targeting emerging markets.

Smart Phasing of Evolved EDGE Rollout

There are two distinctly different GSM markets in the world today. The first market is mature and sophisticated and is typically in developed areas. These mature markets often have UMTS/HSPA footprints in high-use areas and GSM coverage in all areas. The ARPU in these regions is usually high and the user is typically sophisticated and desires multimedia applications in addition to simple applications.

The second is emerging markets, usually in developing countries, where usually only GSM networks are deployed on a broad coverage basis. The reason for not broadly deploying UMTS/HSPA or LTE may include lack of appropriate spectrum or lack of resources due to typically low ARPU rates from their subscribers. However, there is a rapidly growing middle class in such markets that wants more sophisticated data applications on the networks in place today.

A key factor for operators is the roaming revenue, both inbound as well as outbound. Roaming is one major reason for the continued success and relevance of GSM. Users are confident that their applications will work globally and hence are willing to subscribe to worldwide plans. From an emerging market viewpoint an inbound roamer can provide more revenue in one day than the typical local user's monthly ARPU of between \$4 and \$6. From a developed market viewpoint the issue is service continuity and hence handsets have to support both UMTS/HSPA or LTE and GSM.

It is logical to conclude that GSM will continue to be the baseline network technology for many years to come and that this technology will continue to be deployed and upgraded both in developing as well as developed markets.

Phasing of the Evolved EDGE features can be driven by deployment market segment, mobile station market segment, or by other forces of adoption. All of the optional features interoperate with each other.

Some factors to consider:

- Infrastructure vendors can implement most or all of the evolved EDGE features with little capital investment – features may be delivered as software upgrades to base stations
- Mobile station manufacturers will first implement the features that make the most sense for their market segment and technological constraints
- Handhelds will look for features that offer tangible benefits to the handheld user while being suitable for a small form factor and limited battery life
- Laptop (PCMCIA and PCI Express) cards might choose different features because power, heating and size are of less concern
- In emerging markets spectral efficiency and capacity enhancements have the most value in reducing CAPEX as more users can be supported by the same amount of infrastructure. Backhaul would still need to be dimensioned appropriately
- In mature markets, spectrum efficiency and capacity are similarly important, but increased bandwidth and reduced latency are also critical to meet the demands of the more sophisticated user population.

While the infrastructure feature rollout can be usually realized with a software upgrade, implementing most of the features in the mobile station will require a new terminal. The impact on the cost, complexity and size of the new terminal depends on its capabilities. Multi-mode handsets (i.e. supporting UMTS/HSPA and EDGE currently) will be able to more readily incorporate features of Evolved EDGE with less impact on cost and size as they leverage reuse of 3G elements as shown in Figure 9¹².

¹² Source: Information provided courtesy of a 3G Americas member company.

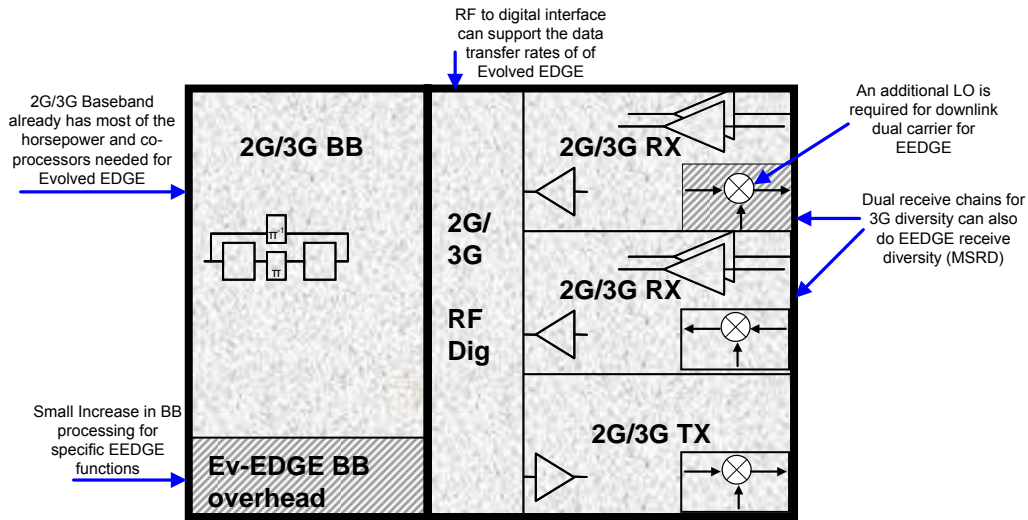

Figure 9 - Chipset View of Additional Evolved EDGE Requirements for a Dual Mode HSPA/Evolved EDGE Product

The additional complexity of adding Evolved EDGE features to 2G only handsets is more significant, as shown in Figure 10. This will have a larger impact on cost, size and time to market for some features, however cost reductions and higher levels of integration will reduce these impacts over time.

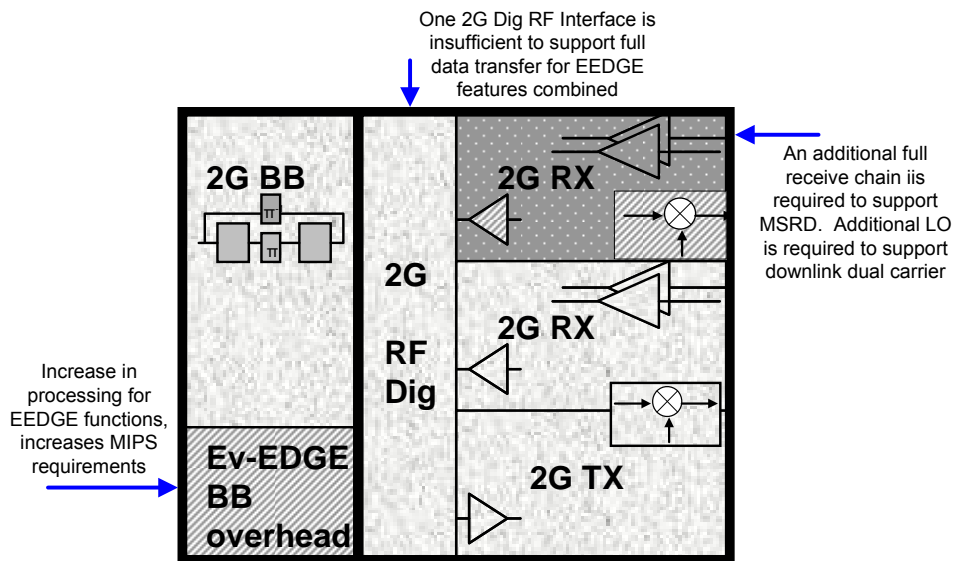

Figure 10 - Chipset View of Additional Evolved EDGE Requirements for a 2G Only Evolved EDGE Product

From a handset point of view, there are many different options for implementing the Evolved EDGE features. As the features are optional and independent, a handset manufacturer may choose to implement the enhancements in phases or release the features all at once. Phasing may be driven by the desire to keep the implementation risk as low as possible and to maximize the benefits of the features as they are introduced. This may lead to different phases of implementation.

Latency reduction and downlink dual carrier may be introduced together. Throughput improvements are limited by the latency of the radio interface; therefore latency reductions should be implemented together with throughput enhancements in order to realize the full gains. The two aspects of latency reduction for Evolved EDGE will result in latency of less than 100ms. Downlink dual carrier results in a downlink capability of 10 slots for most mobile stations. With this phasing choice of features, the downlink peak throughput jumps to almost 600kbps. The advantages that current GSM/EDGE handsets offer today will still be realized. The incremental cost of adding these features is low – 2G handsets have only one radio and can upgrade with small, well understood changes and maintain low IPR costs, while 2G/3G handsets already have many of the requirements to implement this feature subset. The energy required per bit received is expected to remain constant with this feature subset which will preserve the excellent battery life realized today. In addition the mobile station hardware changes required very little additional space, which will mean we preserve the same thin and light handset package; the hardware changes require very little additional space.

Reduced latency could also be combined with MSRD in order to realize capacity and efficiency gains with very low impact on the network side. In this case the mobile station impacts vary depending on the application and the current level of sophistication of the mobile station hardware. Similarly, reduced latency and higher order modulation will have the highest impact on network capacity and spectral efficiency. In general, feature phasing will be driven by many factors and there are many options available.

Evolved EDGE Deployment Considerations

The primary driver to evolve EDGE is to improve the peak, mean and minimum data rates across the global data fabric. Doing this may enable new applications, but it also makes all existing applications work better.

The features that make up Evolved EDGE were selected based on the ability to implement them with low risk, low complexity and at low incremental investment. Most recent BTS designs can support most Evolved EDGE features through software upgrades.

For operators with older GSM equipment, this may be the best time to upgrade to newer BTS. In addition to taking advantage of the data enhancements provided by

Evolved EDGE, newer BTS may realize savings in operational expenditures. The evolution and development of BTS equipment from 1990 to today has provided significant benefits in not only added features, but also in terms of physical size, weight and power consumption¹³.

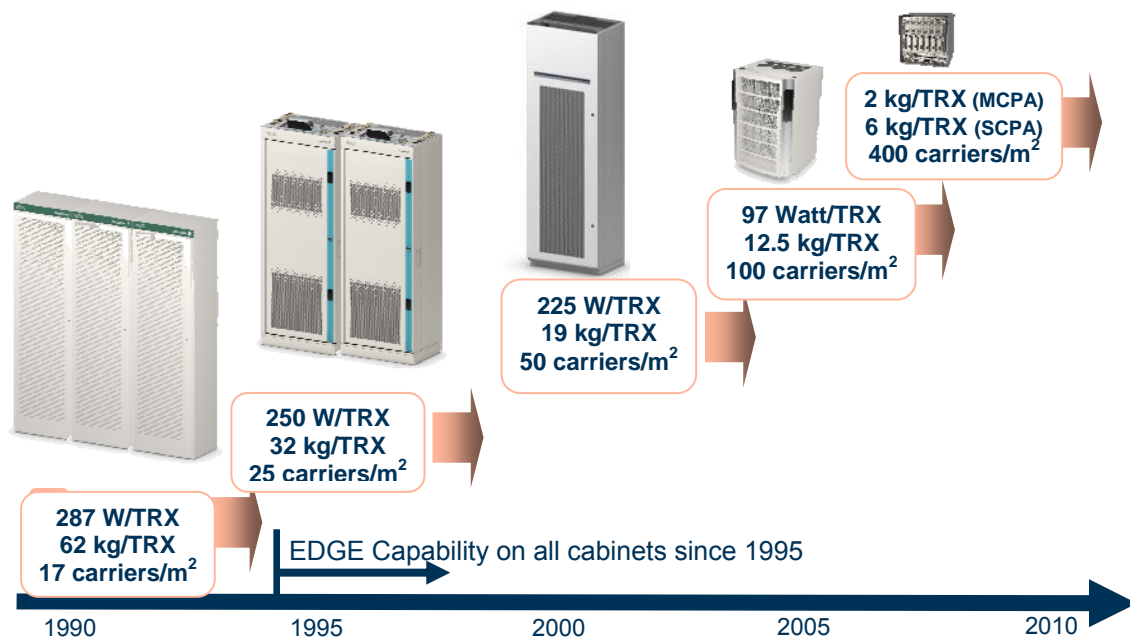

Upgrade decisions by operators tend to be made on a local scale but need to be considered on a global basis. Irrespective of how much an operator upgrades their countrywide network with UMTS/HSPA or LTE, it is service continuity around the globe that is important. Even roaming into a rural area within a geographical area comes with a service continuity requirement. Both inbound and outbound roaming is a must in a broadband mobile world.

For some markets high data speeds are very important. For other markets however this is not the case and value is not equated to data speeds. With the speeds enabled by the upgrade to Evolved EDGE, there are many applications that perform much better on mobile stations:

- Browsing and Web2.0
- Rich social networking interactions
- Wide variety of enterprise applications – e.g. CRM, ERP
- mCommerce applications

¹³ Source: Information provided courtesy of a 3G Americas member company.

- Useful continued functioning of applications designed for HSPA in non-HSPA environments

Applications enabled on laptop cards / modems:

- Mobile internet in rural areas as well as less developed countries
- Laptop use
- Automobile anchored applications

The common access worldwide for the long term is GSM. Upgrading this common access gives benefits in terms of data packages and services that can be offered. Furthermore, there is very little downside to upgrading to Evolved EDGE. The upgrade is simple, straightforward and requires minimal capital expenditure. The rollout of Evolved EDGE features such as downlink dual carrier, latency enhancements, higher order modulation and increased symbol rate and MSRD may be managed by operators in terms of software updates to infrastructure that are scheduled anyway or hardware replacement where end of life is a consideration or the operator wants to take advantage of OPEX improvements.

The Evolved EDGE Value Proposition

The value proposition for Evolved EDGE is centered on the cost / benefit equation for operators and consumers rather than a single metric like data speed. With Evolved EDGE, an operator is able to significantly enhance the value of their existing GSM/GPRS/EDGE system as well as the spectrum it is deployed in. The increase in the data rates offered with this upgrade provide a much better complement for the speeds of HSPA, allow mobile users to more seamlessly enjoy their services while moving around.

Even considering a phased approach to the Evolved EDGE rollout, an operator is able to:

- Provide HSPA and eventually LTE users a much better user experience (less drastic speed drop-off rate) as they roam to areas without HSPA or LTE coverage
- Achieve higher data rates, reduced latency and improved trunking efficiency
- Rapidly deploy the capability across their entire coverage area, with a software upgrade for most BTS
- Continue purchasing low cost handsets:
 - With significantly better data/application capabilities
 - With excellent battery life – as the handset needs just one radio (GSM/GPRS/EDGE/Evolved EDGE)
 - That are able to roam and provide services across the globe
 - That have the same physical characteristics as GSM handsets today – small batteries, thin, light and with the

least number of parts, allowing the smallest physical device package size compared to other technologies

The upgrade to Evolved EDGE is almost risk free and can be scheduled as part of normal operational upgrades of either the base station software alone or together with base station hardware. An operator is then able to offer Evolved EDGE handsets as well as allow inbound roaming of such handsets from other regions of the world.

Acknowledgements

The mission of 3G Americas is to promote and facilitate the seamless deployment throughout the Americas of the GSM family of technologies including LTE. 3G Americas' Board of Governors members include Alcatel-Lucent, AT&T, Cable & Wireless, Ericsson, Gemalto, HP, Huawei, Motorola, Nortel Networks, Nokia, Openwave, Research in Motion (RIM), Rogers (Canada), T-Mobile USA, Telcel (Mexico), Telefónica and Texas Instruments.

This white paper provides an educational reference document on Evolved EDGE but should not be construed as an explicit endorsement by 3G Americas or any of its specific individual members. Evolved EDGE is a part of the 3GPP family of technologies. Individual operators and vendors will make independent decisions regarding the possibility of manufacturing or deploying the wireless technology. Wireless stakeholders and readers of this document should contact individual 3G Americas Board of Governor companies for their specific commercial plans for Evolved EDGE.

We would like to recognize the significant project leadership and important contributions of Johanna Dwyer of Research in Motion (RIM) as well as the other member companies from 3G Americas' Board of Governors who participated in the development of this white paper.

Appendix A

GSM networks, being available almost everywhere, serve in real terms the whole global population in very balanced way. The most populous areas and largest countries are becoming the top users of GSM. With GSM, cellular communication is no longer reserved only for high end users; operators are finding significant growth in the large 'low-cost' segment too.

GSM standardization activities continue to make improvements in response to the needs of cost efficiency of deployment and low operational costs in serving current and new user segments. Currently there are ongoing studies to address these needs for both voice services and data services.

For data services, the Gb interface carrying GSM packet data traffic has been standardized to work over an IP connection since Release 4. In order to benefit from the cost efficiency of IP transport for voice, the A interface between the Media Gateway and Base Station Subsystem needs to be enhanced to work over IP. This work is ongoing in 3GPP and will enable wider use of IP transport in the GSM network. This will replace the TDM based solutions and simplify the transport overall. In addition to the introduction of the IP transport itself, different architectural options are addressed, as the location of the network transcoders impacts the amount of transferred data.

Another topic being studied aims to improve GSM hardware efficiency for voice by accommodating more users per radio carrier. This study is entitled "Multiple Users Reusing One Slot (MUROS) and it can be considered as the next step beyond half rate voice. One GSM frequency carrier originally supported 8 full rate users, and today typically supports 16 half rate users without noticeable loss of voice quality. MUROS could continue this trend by doubling the number of users per carrier, allowing up to 16 full rate users or up to 32 half rate users simultaneously per carrier. The existing full and half rate channel structures would be carried over as such but this time each timeslot would support two simultaneous users. The gains from reducing the need for timeslots can be realized as a smaller number of required TRX, an increased number of voice users, or as additional availability of hardware capacity for multislot and multicarrier data services.